



EUROPEAN CONFERENCE ON COMPUTER VISION

MILANO
2024



Rethinking Deep Unrolled Model for Accelerated MRI Reconstruction

Bingyu Xin¹, Meng Ye¹, Leon Axel², Dimitris N. Metaxas¹

¹Rutgers University ²New York University

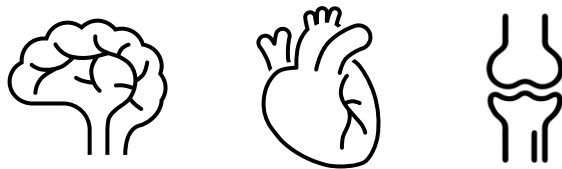

Magnetic Resonance Imaging (MRI)

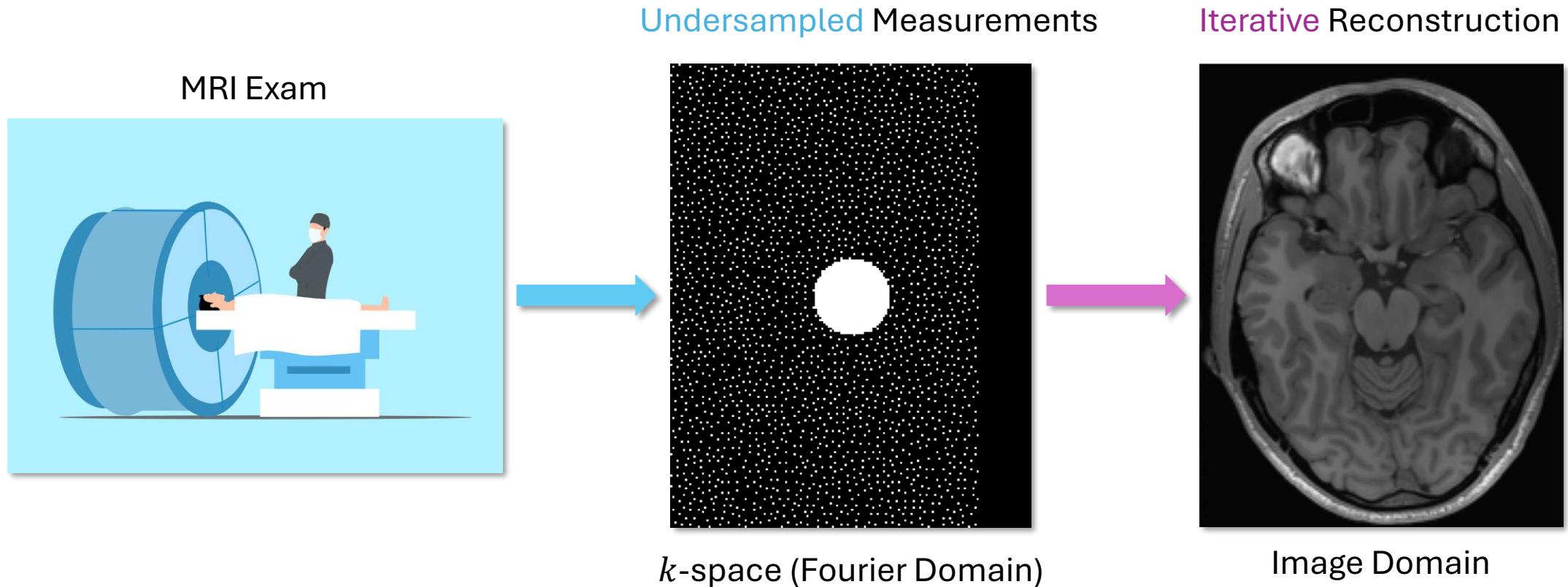

Problem: Accelerated MRI Reconstruction

- Regularized Inverse Problem

$$\min_{\mathbf{x}} \frac{1}{2} \|\mathbf{A}\mathbf{x} - \mathbf{y}\|_2^2 + R(\mathbf{x})$$

We can solve it iteratively via gradient descent

$$\begin{aligned} \mathbf{x}_{t+1} &= \mathbf{x}_t - \eta_t \mathbf{g}_t \\ &= \mathbf{x}_t - \eta_t [\mathbf{A}^H (\mathbf{A}\mathbf{x}_t - \mathbf{y}) + \nabla R(\mathbf{x}_t)] \end{aligned}$$

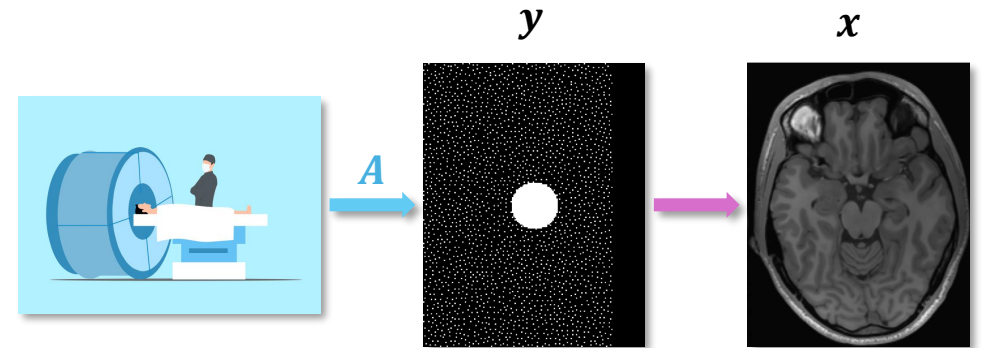

Preliminary: Deep Unrolled Model

- Unroll each iteration with a **neural network**

Iterative Reconstruction

$$\mathbf{x}_{t+1} = \mathbf{x}_t - \eta_t [\mathbf{A}^H (\mathbf{A} \mathbf{x}_t - \mathbf{y}) + \nabla R(\mathbf{x}_t)]$$

Deep Unrolling

$$\mathbf{x}_{t+1} = \mathbf{x}_t - \eta_t \mathbf{A}^H (\mathbf{A} \mathbf{x}_t - \mathbf{y}) + \mathbf{CNN}(\mathbf{x}_t)$$

Deep Unrolled Model

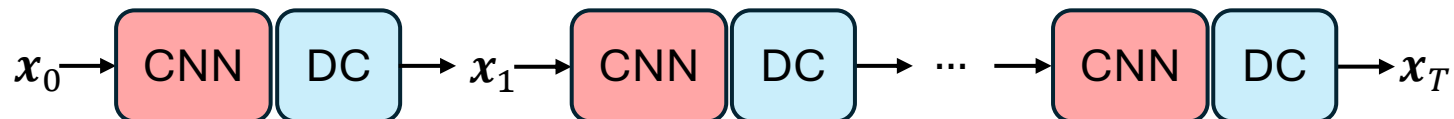

Contributions



1. Adaptive Unrolling



2. Memory-Efficient Sensitivity Map Estimation



3. SOTA Performance on Three Public Benchmarks

Motivation

- Areas of **complex** structure need more **careful** gradient-based correction

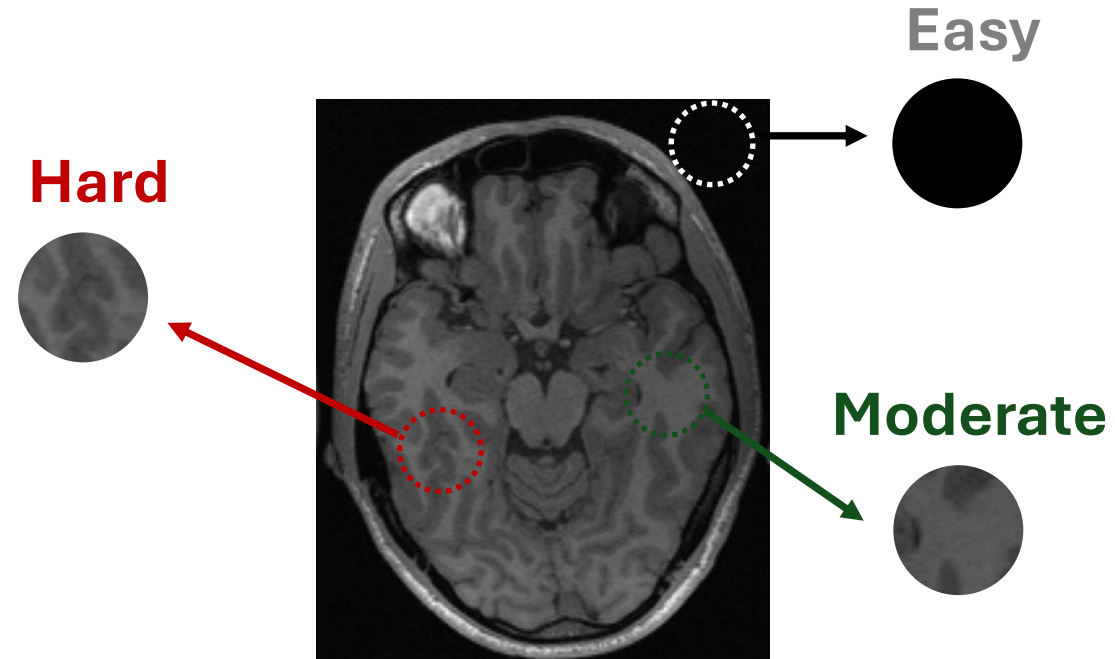

Method: Adaptive Unrolling

- Adaptive Gradient Algorithm

Apply pixel-wise learning rate in each iteration

Gradient Descent

$$\mathbf{x}_{t+1} = \mathbf{x}_t - \eta_t \mathbf{g}_t$$

scalar learning rate η_t

Adaptive Gradient Descent

$$\mathbf{x}_{t+1} = \mathbf{x}_t - \eta_t \mathbf{g}_t - \mathbf{E}_t \odot \mathbf{g}_t$$

residual pixel-wise learning rate \mathbf{E}_t

$$\mathbf{E}_t = \frac{\eta_t}{\sqrt{\sum_{\tau=0}^t \mathbf{g}_{\tau}^2} + \epsilon} - \eta_t$$

Method: Adaptive Unrolling

- Reparametrization

Deep Unrolling

$$\mathbf{x}_{t+1} = \mathbf{x}_t - \eta_t \mathbf{A}^H (\mathbf{A} \mathbf{x}_t - \mathbf{y}) + \text{CNN}(\mathbf{x}_t)$$

Adaptive Unrolling

$$\mathbf{x}_{t+1} = \mathbf{x}_t - \eta_t \mathbf{A}^H (\mathbf{A} \mathbf{x}_t - \mathbf{y}) + \text{CNN}(\mathbf{x}_t, \mathbf{A}^H \mathbf{A} \mathbf{x}_t, \mathbf{A}^H \mathbf{y}, \mathbf{s}_t)$$

Deep Unrolled Model

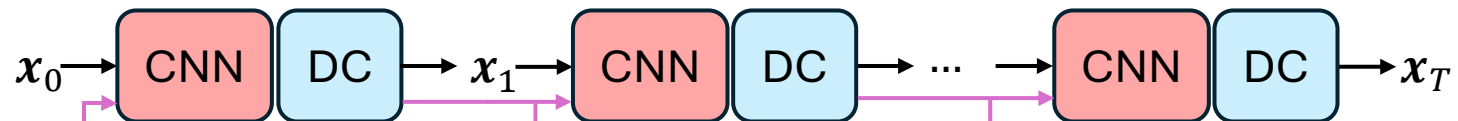

Adaptive Unrolled Model

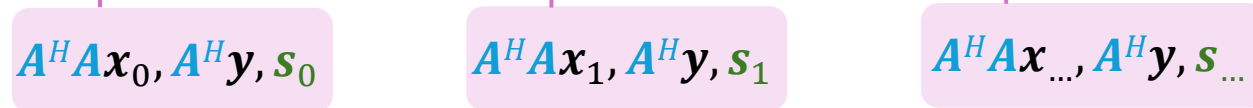

\mathbf{s}_t tracks the historical gradient information implicitly

Method: Adaptive Unrolling

- Momentum-Accelerated Gradient Algorithm

Historical feature aggregation

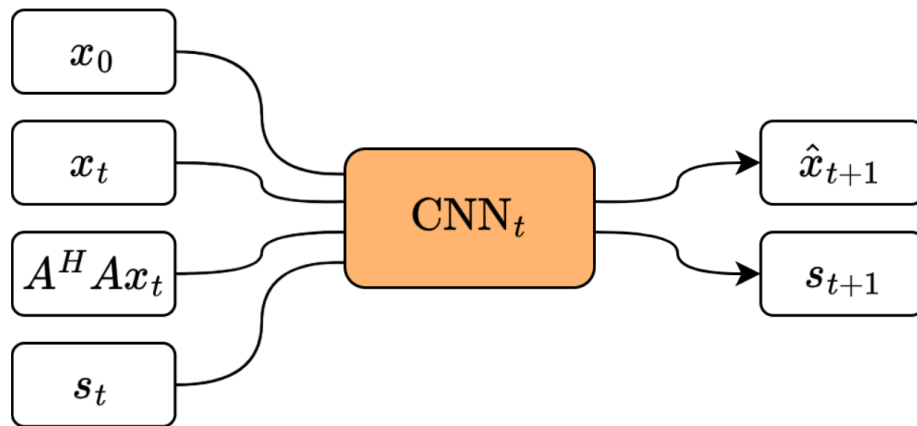

(a) Self-Adaptive Gradient Algorithm

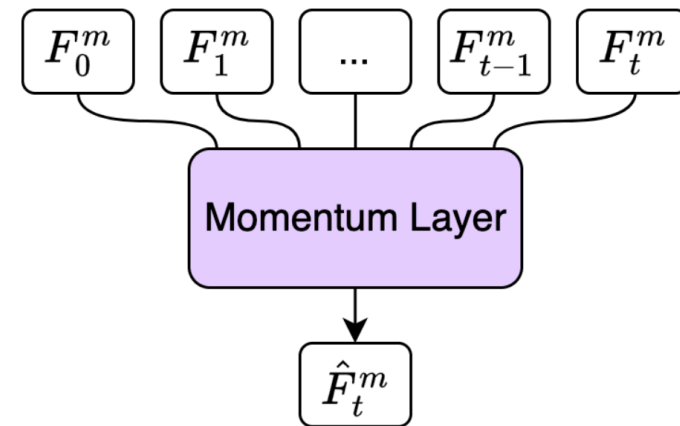

(b) Momentum-Accelerated Gradient Algorithm

Method: Adaptive Unrolling

- Results

Deep Unrolled Model: **M1**, **M2**
Adaptive Unrolled Model: **Ours**

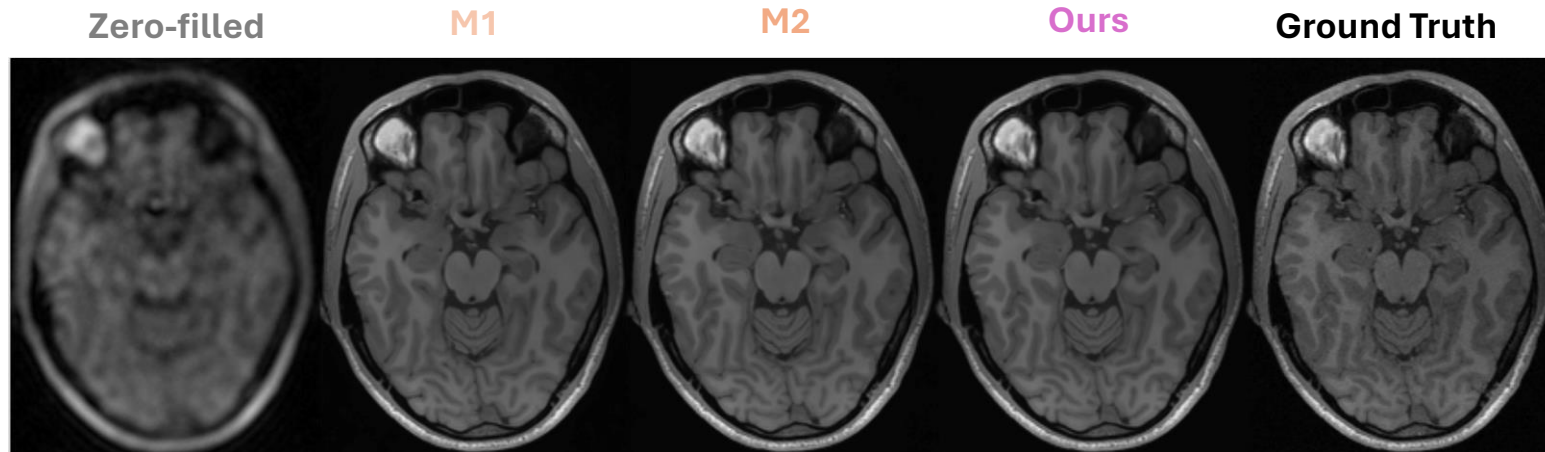

M1: learns a weaker prior, resulting in a blurry structure

M2: learns an overly biased prior, resulting in a sharper but incorrect structure

Ours: learns an appropriate prior, resulting in a sharp and correct structure

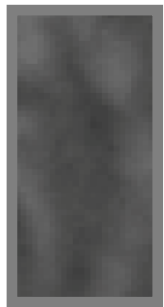

Contribution1: Adaptive unrolling

Method: Sensitivity Map Estimation

- Adjacent slice correlation

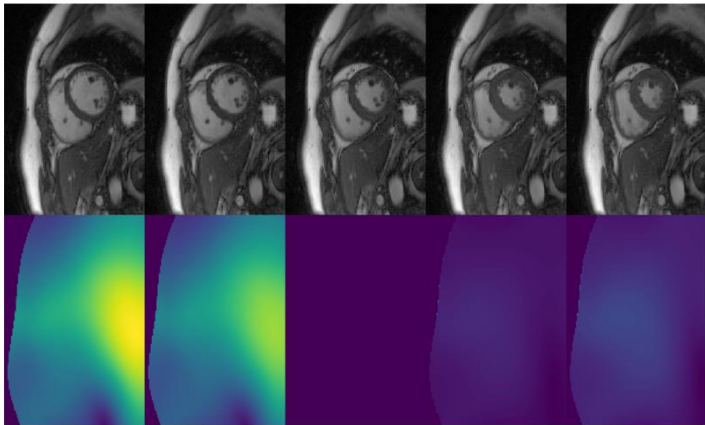

(a) time

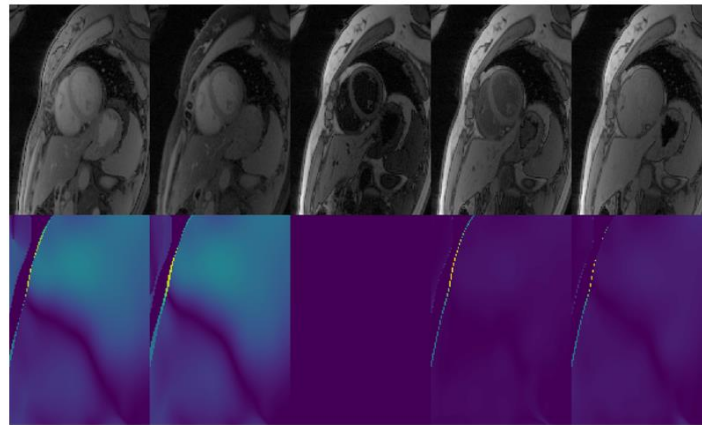

(b) contrast

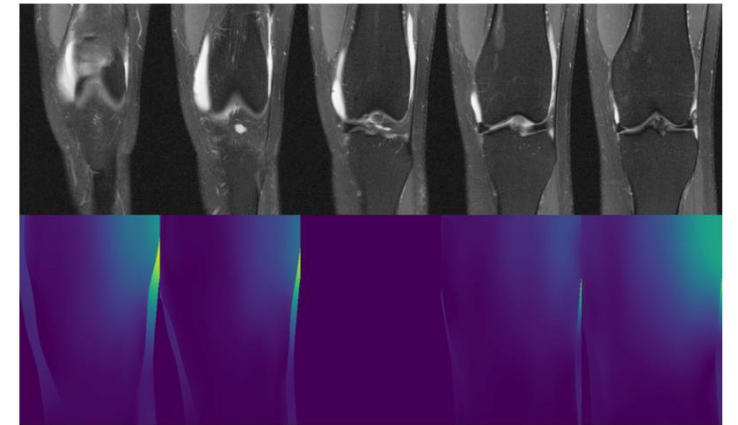

(c) slice

Method: Sensitivity Map Estimation

- Memory bottleneck

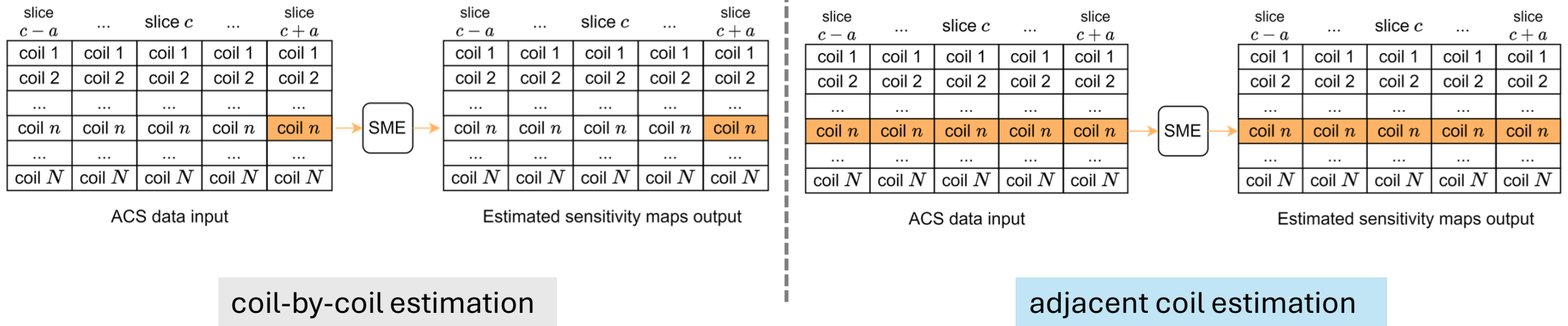

Method: Sensitivity Map Estimation

- Memory bottleneck

Memory reduced by 55%

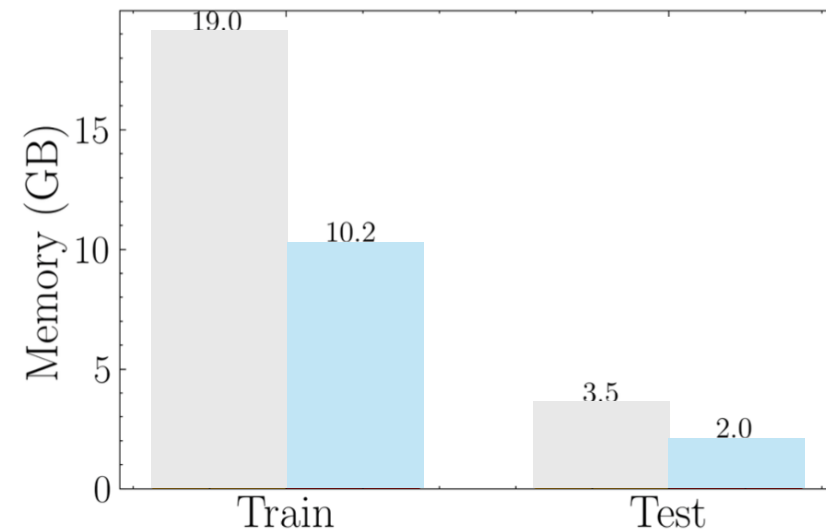

coil-by-coil estimation

adjacent coil estimation

SOTA Results:

CMRxRecon **Cardiac**

Calgary-Campinas **Brain**

Method	Acc = 5×		Acc = 10×	
	PSNR(dB)	SSIM(%)	PSNR(dB)	SSIM(%)
Zero-filled	25.27±1.31	73.75±3.93	24.35±1.21	69.04±3.67
Recurrent-Varnet [34]	36.27±1.72	94.37±1.33	33.27±2.12	91.47±2.23
PromptMR [31]	36.83±1.68	94.85±1.26	34.10±2.11	92.69±1.92
Ours	37.24±1.57	95.15±1.21	34.74±1.97	93.38±1.65

Acc	Method	Cine				Mapping			
		SAX		LAX		T1w		T2w	
		PSNR(dB)	SSIM(%)	PSNR(dB)	SSIM(%)	PSNR(dB)	SSIM(%)	PSNR(dB)	SSIM(%)
4×	Zero-filled	26.20±1.54	72.99±5.14	25.11±1.62	69.87±4.73	24.23±1.16	67.27±3.84	24.97±1.10	77.16±2.91
	PromptMR [31]	45.78±1.89	98.78±0.43	45.58±1.72	98.72±0.37	46.49±2.23	98.93±0.57	42.02±1.93	98.05±0.72
	Ours	46.26±1.76	98.87±0.34	46.13±1.70	98.83±0.34	47.45±2.13	99.09±0.42	42.68±1.84	98.25±0.59
8×	Zero-filled	25.18±1.67	70.21±5.87	24.34±1.66	67.67±5.80	23.41±1.25	64.12±4.43	24.21±1.12	74.84±3.07
	PromptMR [31]	40.65±1.52	96.97±0.68	39.64±1.87	96.36±1.04	40.94±1.69	97.28±0.85	38.24±1.82	96.53±1.09
	Ours	41.44±1.48	97.32±0.58	40.49±1.83	96.76±0.94	42.08±1.63	97.70±0.67	39.23±1.71	96.98±0.89
10×	Zero-filled	24.83±1.67	69.35±5.92	24.13±1.67	66.89±5.58	23.16±1.27	64.14±4.47	24.25±1.14	76.08±2.91
	PromptMR [31]	39.18±1.50	96.15±0.80	38.28±1.62	95.60±1.07	38.99±1.58	96.61±0.99	37.21±1.76	96.22±1.16
	Ours	39.99±1.49	96.58±0.72	39.13±1.66	96.05±0.99	40.37±1.58	97.19±0.79	38.22±1.70	96.70±0.96

FastMRI **Knee**

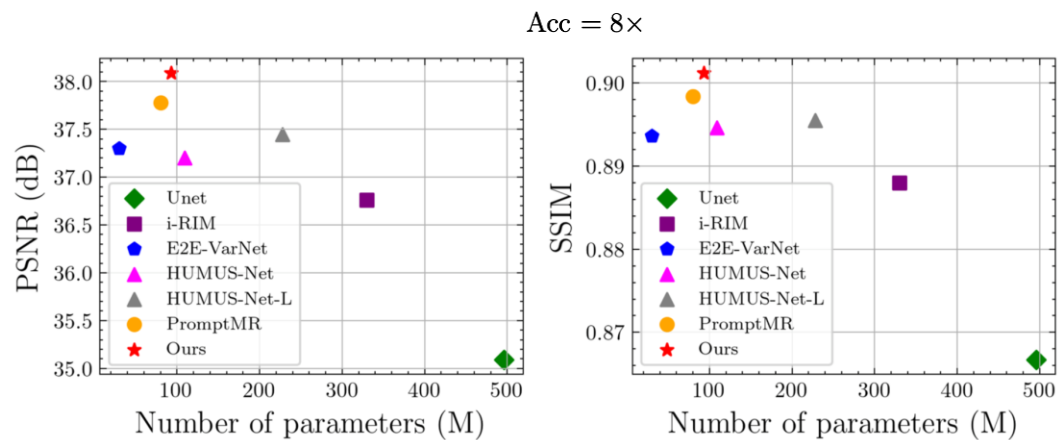

Method	Acc = 4×				Acc = 8×			
	PD		PDFS		PD		PDFS	
	PSNR(dB)	SSIM(%)	PSNR(dB)	SSIM(%)	PSNR(dB)	SSIM(%)	PSNR(dB)	SSIM(%)
Zero-filled	30.86±1.73	80.65±3.76	31.00±3.33	78.48±6.16	27.70±1.84	74.12±4.94	27.97±2.02	68.78±5.58
Unet [55]	37.27±1.76	92.11±2.72	37.07±2.47	88.03±5.04	35.41±2.14	90.36±3.13	34.84±1.59	83.71±5.04
i-RIM [56]	39.61±2.33	94.16±2.87	38.23±3.13	89.27±4.96	37.91±2.47	93.22±2.85	35.84±1.71	85.27±4.93
E2E-VarNet [45]	40.09±2.32	94.56±2.64	38.43±3.24	89.50±4.95	38.72±2.50	93.93±2.68	36.16±1.76	85.70±4.94
HUMUS-Net [30]	-	-	-	-	38.72±2.50	94.07±2.68	35.98±1.75	85.77±4.93
HUMUS-Net-L [30]	-	-	-	-	39.03±2.47	94.18±2.61	36.19±1.79	85.84±4.92
PromptMR [31]	40.58±2.59	94.87±2.75	38.59±3.33	89.75±4.94	39.48±2.54	94.51±2.54	36.42±1.79	86.10±4.93
Ours	40.85±2.74	95.00±2.84	38.71±3.37	89.85±4.92	40.09±2.58	94.90±2.45	36.49±1.88	86.29±4.95

Contribution3: SOTA Performance on Three Public Benchmarks

SOTA Results: Calgary-Campinas Brain

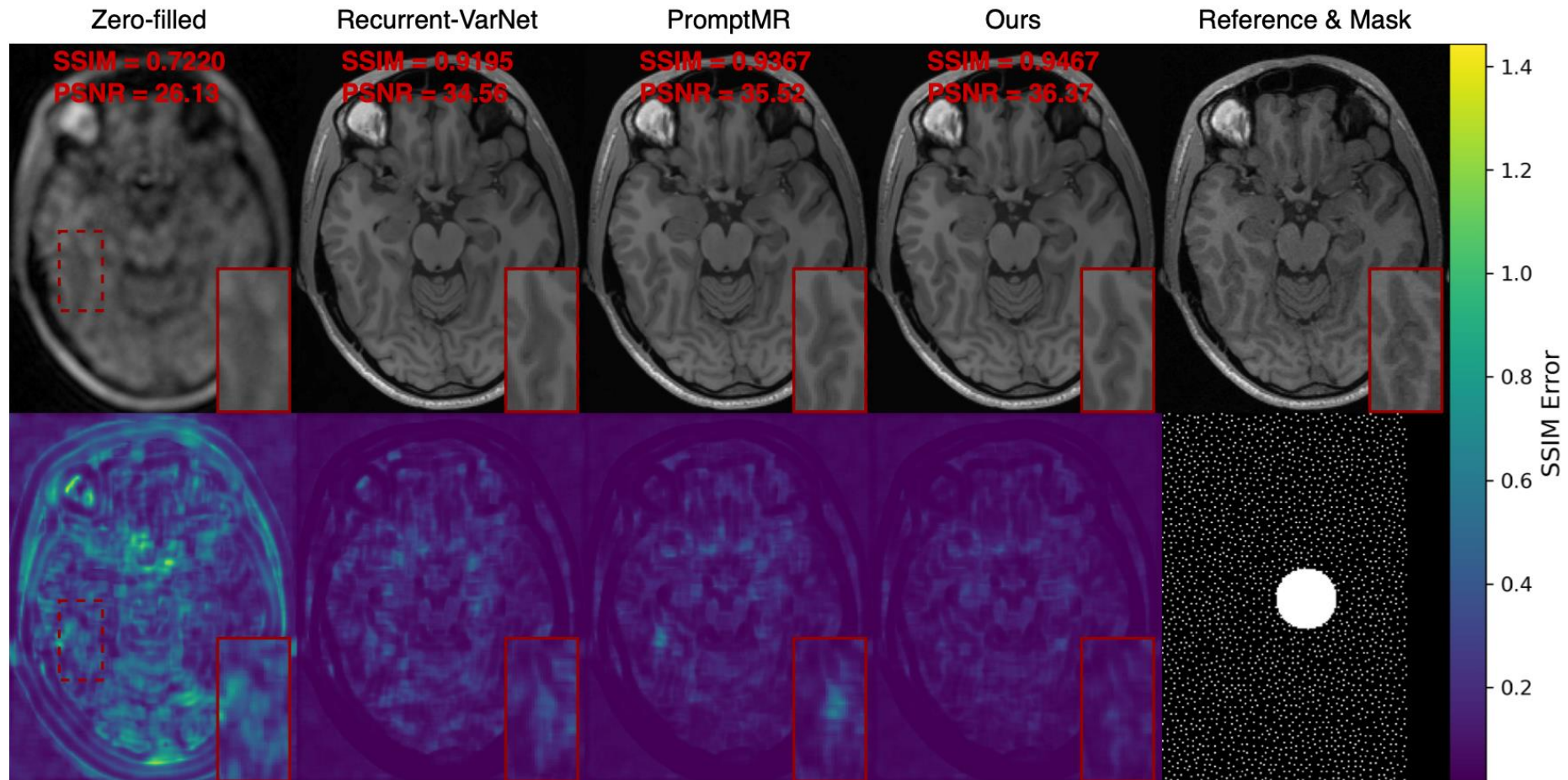

Contribution3: SOTA Performance on Three Public Benchmarks

SOTA Results: CMRxRecon **Cardiac**

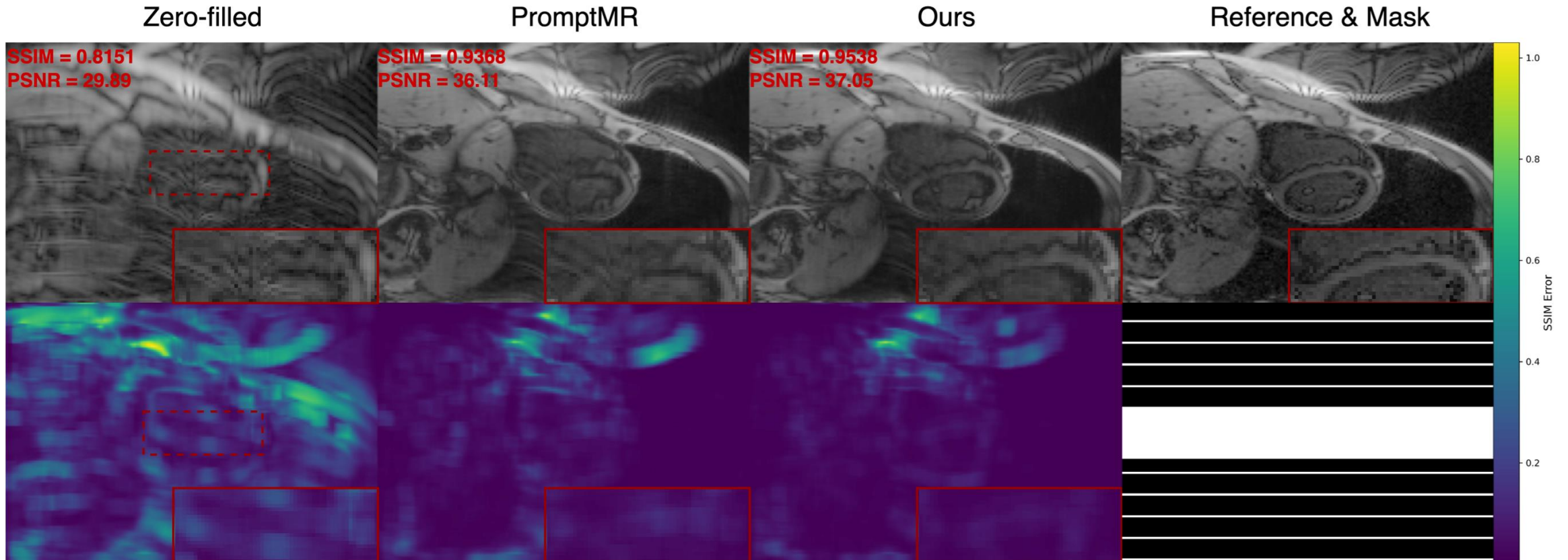

SOTA Results: FastMRI Knee

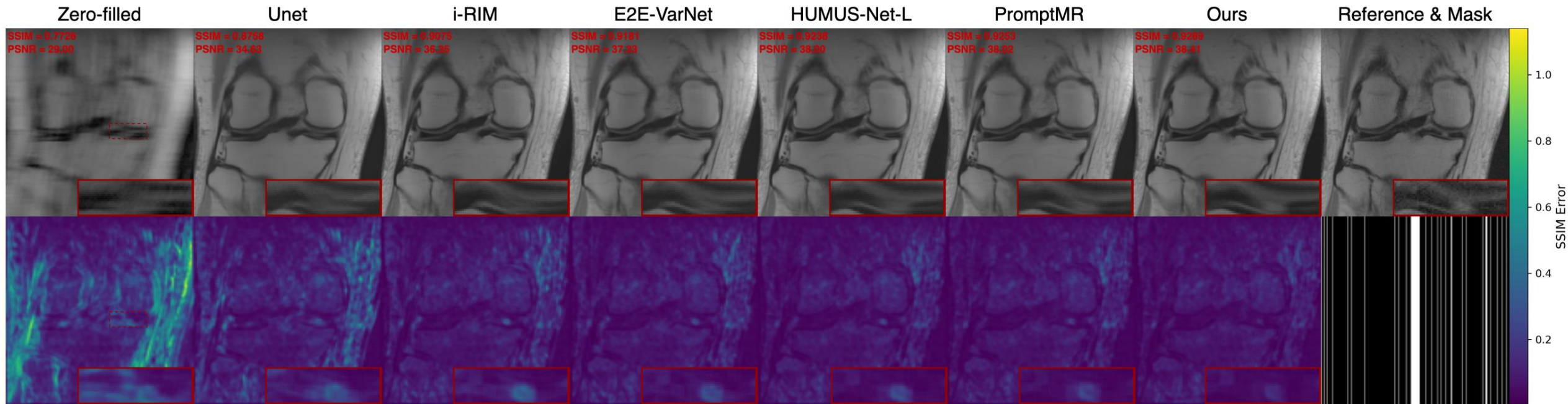

Summary

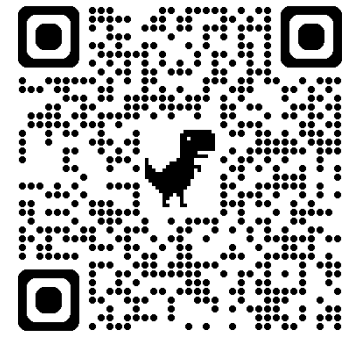

Code & Models

Adaptive Unrolling

Memory-Efficient Sensitivity Map Estimation

SOTA Performance on 3 Public Benchmarks